

DIMENSIONS UNIT: mm							MODEL No.
NOMINAL DIAMETER	L	FLANGE		REFERENCE			
		øC	n1-h1	H1	H2	B	
50A(2")	43	120.7	4-5/8"(UNC)	65	161	265	G10-FL-02-L
65A(2 1/2")	46	139.7	4-5/8"(UNC)	75	173	265	G10-FL-2.5-L
80A(3")	46	152.4	4-5/8"(UNC)	105	183	265	G10-FL-03-L
100A(4")	52	190.5	8-5/8"(UNC)	115	198	265	G10-FL-04-L
125A(5")	56	215.9	8-3/4"(UNC)	140	210	265	G10-FL-05-L
150A(6")	56	241.3	8-3/4"(UNC)	157	223	265	G10-FL-06-L
200A(8")	60	298.5	8-3/4"(UNC)	185	263	400	G10-FL-08-L

FLANGE RATING : ASME B16.5 CL150

P.NO	PART NAME	MATERIAL	Q'TY	REMARK
1	BODY	DUCTILE IRON	1	FC450 A395/536
2	DISC	ST.ST. / ALBC	1	SCS13/14, ALBC NOTE.5
3	SEAT	RUBBER	1	NBR/EPDM/WITON NOTE.5
4	STEM (UPPER)	ST.ST.	1	SUS304/316/410 NOTE.5
5	STEM (LOWER)	ST.ST.	1	SUS304/316/410 NOTE.5
6	BUSH	BRONZE	1SET	(C83600)
8	ANTI-BLOW OUT RING	ST.ST.	1SET	(A240 T304)
9	GLAND RING	ST.ST.	2	(A240 T304)
11	BOTTOM COVER	ST.ST.	1	(A276 T304)
13	PACKING	RUBBER	1SET	-
14	GLAND BOLT	ST.ST.	1SET	(A193 B8)
15	ACTUATOR STAND BOLT	ST.ST.	1SET	(A193 B8)
20	LEVER	SS400	1	

NOTES

- The Flange rating on the drawing shall be in accordance with National Standard.
The rating shall be provided conforming 5K/10K/16K for JIS B2220 5K/10K/16K, 150LB for ANSI B 16.5 150LB, PN6/10/16 for ISO 7005 PN6/10/16.
- VALVE TEST : AS PER JIS F7480
- Shell Test (Working Pressure X 1.5)
EX. JIS 5K : 7.5 kg/cm2
- Seat Test (Working Pressure X 1.1)
EX. JIS 5K : 5.5 kg/cm2
- Flange Finish
- Wafer type : N/A
- Lug type : RF
- Flange type : FF
- Appearance of valve Flange rating Hole according to reference drawing
- Valve materials are subject to customer requirements.
- Please fill out the model number, flange Rating, and material on the order form

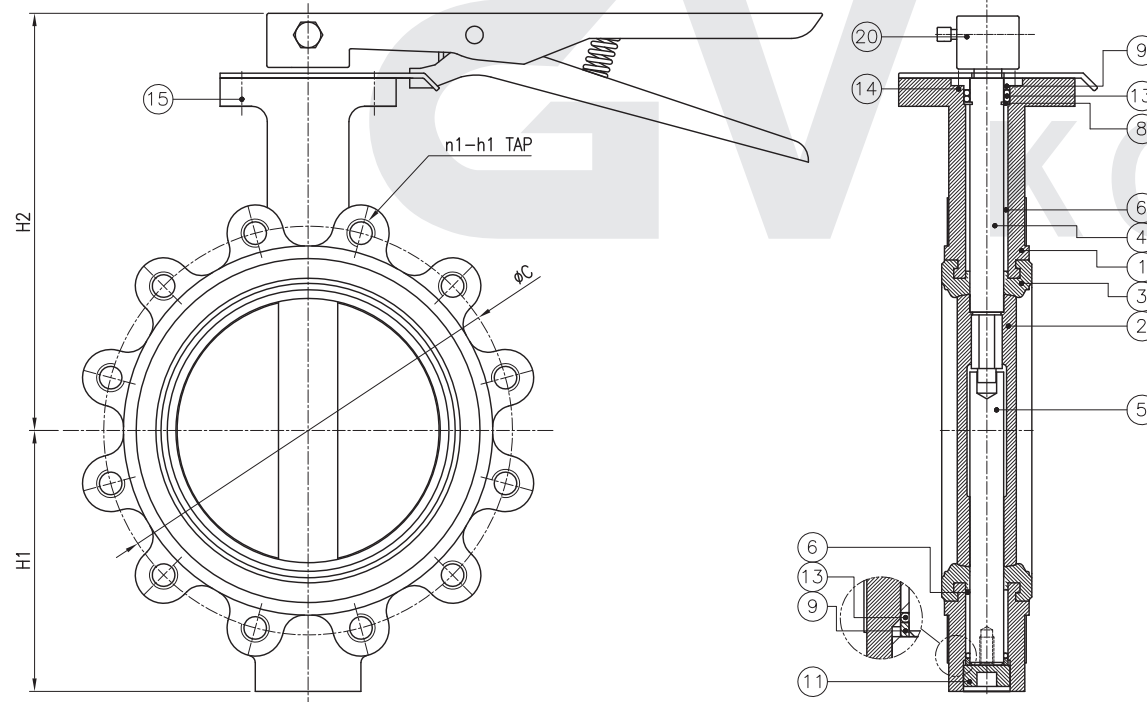

3						
2						
1	2022.05.06	FOR CONTRACT				
NO	DATE	DESCRIPTION	DRA.	DES.	CHK.	APP.
TITLE		CONCENTRIC FULL-LUG TYPE ASME CL150				
SUB.TITLE		LEVER OPERATED BUTTERFLY VALVE				
DRA.	DES.	CHK.	APP.	SCALE	N. S	
J.H KIM		KEVIN.C	CG.LEE	DATE	2023.11.10	
				DWG/N	CLN0208KBA	

GW Korea Co.,Ltd.

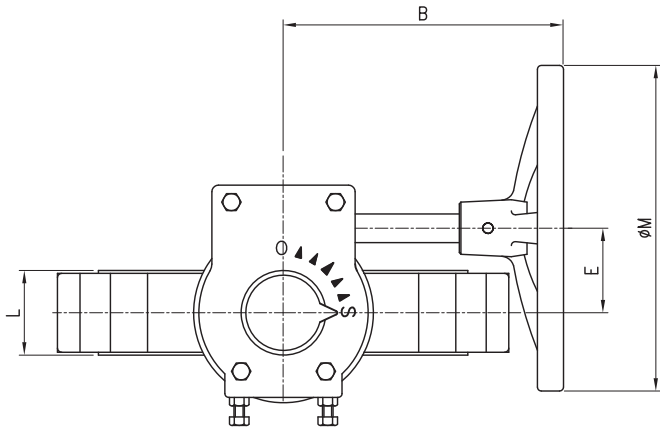

DIMENSIONS										UNIT: mm	MODEL No.
NOMINAL DIAMETER	L	FLANGE		REFERENCE							
		øC	n1-h1	H1	H2	H3	B	E	øM		
50A(2")	43	120.7	4-5/8"(UNC)	65	156	28	135	45	150	G10-FL-02-G	
65A(2 1/2")	46	139.7	4-5/8"(UNC)	75	168	28	135	45	150	G10-FL-2.5-G	
80A(3")	46	152.4	4-5/8"(UNC)	105	178	28	135	45	150	G10-FL-03-G	
100A(4")	52	190.5	8-5/8"(UNC)	115	193	28	135	45	150	G10-FL-04-G	
125A(5")	56	215.9	8-3/4"(UNC)	140	205	28	135	45	150	G10-FL-05-G	
150A(6")	56	241.3	8-3/4"(UNC)	157	218	28	135	45	150	G10-FL-06-G	
200A(8")	60	298.5	8-3/4"(UNC)	185	266	36	205	65	200	G10-FL-08-G	
250A(10")	68	362	12-7/8"(UNC)	220	306	36	205	65	200	G10-FL-10-G	
300A(12")	78	431.8	12-7/8"(UNC)	225	346	36	205	65	200	G10-FL-12-G	
350A(14")	78	476.3	12-1"(UNC)	276	371	36	205	65	200	G10-FL-14-G	

FLANGE RATING : ASME B16.5 CL150

P.NO	PART NAME	MATERIAL	Q'TY	REMARK
1	BODY	DUCTILE IRON	1	FC450 A395/S36
2	DISC	ST.ST. /ALBC	1	SCS13/14, ALBC NOTE.5
3	SEAT	RUBBER	1	NBR/EPDM/WITON NOTE.5
4	STEM (UPPER)	ST.ST.	1	SUS304/316/410 NOTE.5
5	STEM (LOWER)	ST.ST.	1	SUS304/316/410 NOTE.5
6	BUSH	BRONZE	1SET	(C83600)
8	ANTI-BLOW OUT RING	ST.ST.	1SET	(A240 T304)
9	GLAND RING	ST.ST.	2	(A240 T304)
11	BOTTOM COVER	ST.ST.	1	(A276 T304)
13	PACKING	RUBBER	1SET	-
14	GLAND BOLT	ST.ST.	1SET	(A193 B8)
15	ACTUATOR STAND BOLT	ST.ST.	1SET	(A193 B8)
20	GEAR BOX	ASS'Y	1	

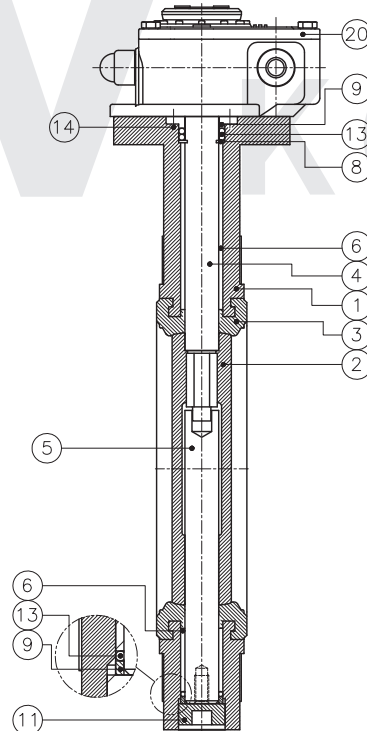
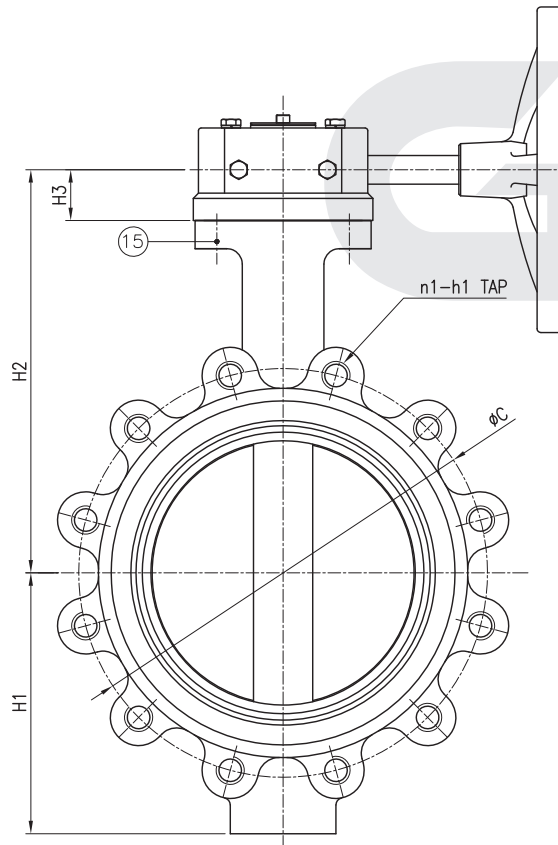

NOTES

- The Flange rating on the drawing shall be in accordance with National Standard.
The rating shall be provided conforming 5K/10K/16K for JIS B2220 5K/10K/16K, 150LB for ANSI B 16.5 150LB, PN6/10/16 for ISO 7005 PN6/10/16.
- VALVE TEST : AS PER JIS F7480
- Shell Test (Working Pressure X 1.5)
EX. JIS 5K : 7.5 kg/cm²
- Seat Test (Working Pressure X 1.1)
EX. JIS 5K : 5.5 kg/cm²
- Flange Finish
- Wafer type : N/A
- Lug type : RF
- Flange type : FF
- Appearance of valve Flange rating Hole according to reference drawing
- Valve materials are subject to customer requirements.
- Please fill out the model number, flange Rating, and material on the order form

NO	DATE	DESCRIPTION	DRA.	DES.	CHK.	APP.
TITLE		CONCENTRIC FULL-LUG TYPE ASME CL150				
SUB.TITLE		GEAR OPERATED BUTTERFLY VALVE				
DRA.	DES.	CHK.	APP.	SCALE	N. S	
J.H KIM		KEVIN.C	CG.LEE	DATE	2023.11.10	
				DWG/N	CLN0214KCA	

GW Korea Co.,Ltd.

DIMENSIONS										UNIT: mm	MODEL No.
NOMINAL DIAMETER	L	FLANGE		REFERENCE						øM	
		øC	n1-h1	H1	H2	H3	B	E			
400(16")	102	495	16-M22	330	416	46	255	80	300	G10-FL-16-G	
450(18")	114	555	16-M22	380	436	46	255	80	300	G10-FL-18-G	
500(20")	127	605	20-M22	415	485	65	320	120	400	G10-FL-20-G	
550(22")	154	665	20-M24	440	527	65	320	120	400	G10-FL-22-G	
600(24")	154	715	20-M24	470	560	65	320	120	400	G10-FL-24-G	
650(26")	165	770	24-M24	487	590	65	320	120	400	G10-FL-26-G	
700(28")	165	820	24-M24	512	620	65	345	30	400	G10-FL-28-G	
750(30")	190	880	24-M30	550	655	65	345	30	400	G10-FL-30-G	
800(32")	190	930	24-M30	591	705	65	345	30	400	G10-FL-32-G	

FLANGE RATING : JIS 5K SAMPLE

P.NO	PART NAME	MATERIAL	Q'TY	REMARK
1	BODY	DUCTILE IRON	1	FCI450 A395/S36
2	DISC	ST.ST. /ALBC	1	SCS13/14, ALBC NOTE.5
3	SEAT	RUBBER	1	NBR/EPDM/WITON NOTE.5
4	STEM (UPPER)	ST.ST.	1	SUS304/316/410 NOTE.5
5	STEM (LOWER)	ST.ST.	1	SUS304/316/410 NOTE.5
6	BUSH	BRONZE	1SET	(C83600)
8	ANTI-BLOW OUT RING	ST.ST.	1SET	(A240 T304)
9	GLAND RING	ST.ST.	2	(A240 T304)
11	BOTTOM COVER	ST.ST.	1	(A276 T304)
13	PACKING	RUBBER	1SET	-
14	GLAND BOLT	ST.ST.	1SET	(A193 B8)
15	ACTUATOR STAND BOLT	ST.ST.	1SET	(A193 B8)
20	GEAR BOX	ASS'Y	1	

NOTES

- The Flange rating on the drawing shall be in accordance with National Standard.
The rating shall be provided conforming 5K/10K/16K for JIS B2220 5K/10K/16K, 150LB for ANSI B 16.5 150LB, PN6/10/16 for ISO 7005 PN6/10/16.
- VALVE TEST : AS PER JIS F7480
- Shell Test (Working Pressure X 1.5)
EX. JIS 5K : 7.5 kg/cm2
- Seat Test (Working Pressure X 1.1)
EX. JIS 5K : 5.5 kg/cm2
- Flange Finish
- Wafer type : N/A
- Lug type : RF
- Flange type : FF
- Appearance of valve Flange rating Hole according to reference drawing
- Valve materials are subject to customer requirements.
- Please fill out the model number, flange Rating, and material on the order form

NO	DATE	DESCRIPTION	DRA.	DES.	CHK.	APP.
TITLE		CONCENTRIC FULL-LUG TYPE ASME CL150				
SUB.TITLE		GEAR OPERATED BUTTERFLY VALVE				
DRA.	DES.	CHK.	APP.	SCALE	N. S	
J.H KIM		KEVIN.C	CG.LEE	DATE	2023.11.10	
				DWG/N	CLN1632KCA	

GW Korea Co.,Ltd.

<REFERCNC E FOR VALVE OUT DRAWING>

WAFER

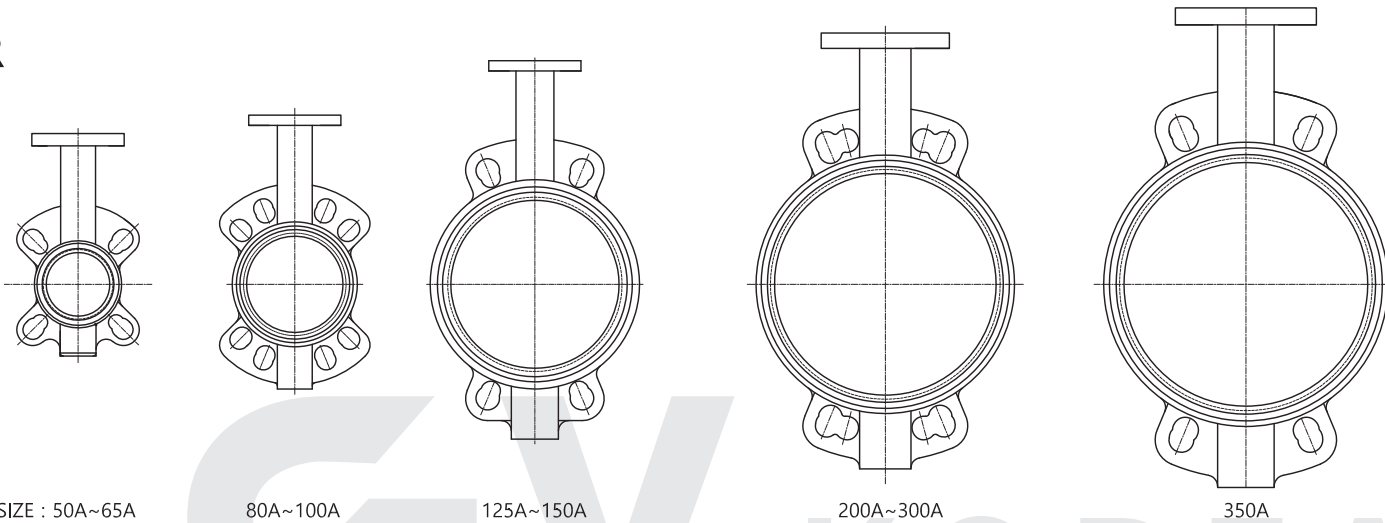

SIZE : 50A~65A

80A~100A

125A~150A

200A~300A

350A

LUG

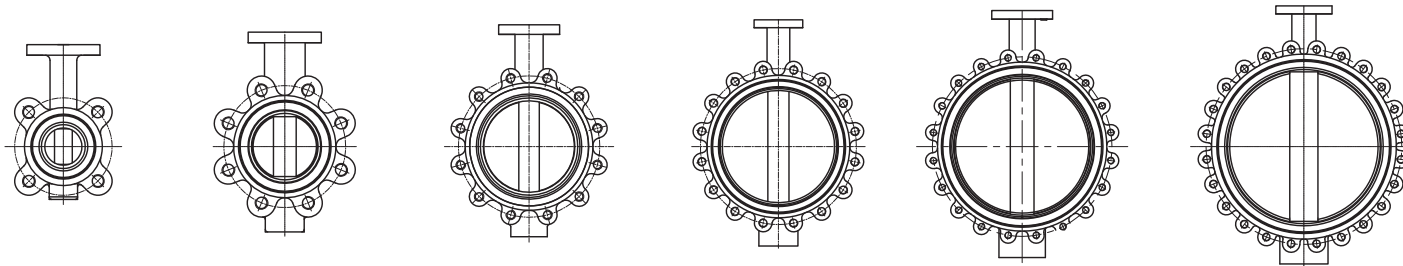

- 5K 50A~80A.
- 10K 50A~65A.
- 150LB 50A~80A.

- 5K 100A~200A.
- 10K 80A~150A.
- 150LB 100A~200A.

- 5K 250A~350A.
- 10K 200A~250A.
- 150LB 250A~350A.

- 5K 400A~450A.
- 10K 300A~400A.
- 150LB 400A~450A.

- 5K 500A~600A.
- 10K 450A~550A.
- 150LB 500A~600A.

- 5K 650A~850A.
- 10K 600A~750A.
- 150LB -

NO	DATE	DESCRIPTION	DRA.	DES.	CHK.	APP.
TITLE		CONCENTRIC REFERENCE DRAWING				
SUB.TITLE		CONCENTRIC BUTTERFLY VALVE				
DRA.	DES.	CHK.	APP.	SCALE	N. S	
J.H KIM		KEVIN.C	CG.LEE	DATE	2022.04.27	
				DWG/N	REF-OUT-RO	
GV Korea Co.,Ltd.						